

INTERNATIONAL "A" CLASS MEASUREMENT CERTIFICATE

IYRU MODEL YACHT RACING DIVISION

Reg. Number.....Date First Measurement.....

Name of Boat.....

Design.....

Designer.....

Owner's Name.....

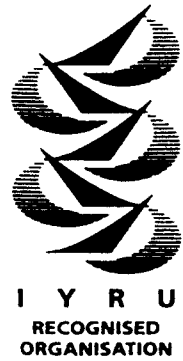

Division Member.....

Division Member Stamp

Signed.....

Name.....

Position.....Date.....

Effective 1 June 1994

© IYRU 1994

CHANGE OF OWNERSHIP

Division Member Stamp

New Owner's Name.....

I undertake to race this boat only if I maintain it in conformity with the Class Rules and that only sails, spars etc, which have been checked by an official measurer will be used.

New Owner's Signature.....

Division Member.....

Signed.....Position.....

Name.....Date.....

CHANGE OF OWNERSHIP

Division Member Stamp

New Owner's Name.....

I undertake to race this boat only if I maintain it in conformity with the Class Rules and that only sails, spars etc, which have been checked by an official measurer will be used.

New Owner's Signature.....

Division Member.....

Signed.....Position.....

Name.....Date.....

MEASURED LENGTH

Measured Waterline Length LWL

Q.B.L. Port
 Q.B.L. Starboard
 Q.B.L. Mean
 Q.B.L. Allowed $100 - \sqrt{0.02 \text{ LWL}}$
 Excess
 0.5. Excess
 Measured Length (L) for Formula

Average Freeboard
 Min. Freeboard without penalty ($0.28\sqrt[3]{VD+23}$)
 Penalty

Draught Measured
 Draught without penalty ($0.16 \text{ LWL} + 89$)
 Excess
 Excess $\times 3$
 Penalty

Total Penalty

DISPLACEMENT

Weight of Boat $\times 10^6$
 Cube Root Displacement $\sqrt[3]{\quad}$

Maximum $\sqrt[3]{VD}$ used for Rating
 Enter Smaller of two figures

0.2 LWL + 25

Minimum $\sqrt[3]{VD}$ without Penalty

0.2 LWL + 10
 Actual $\sqrt[3]{VD}$
 Difference

$\sqrt[3]{VD}$ for Formula

FREEBOARD

Measured
 Fore
 Mid
 Aft
 Port
 Starboard
 Mean
 Average Freeboard $\div 3$

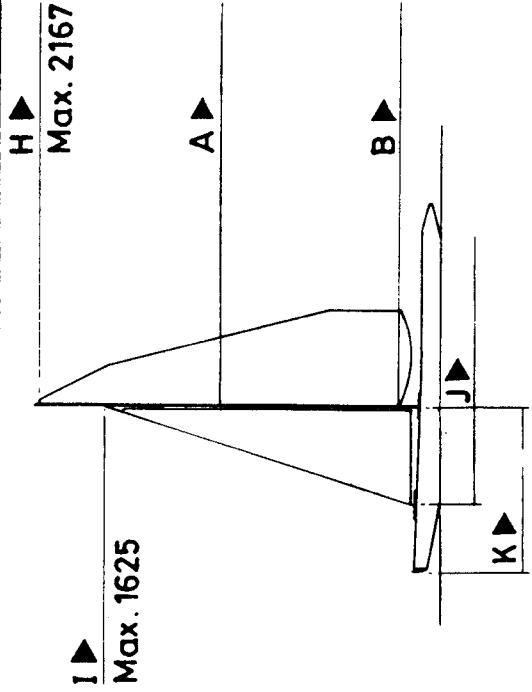

Main Sail $\frac{A \times B}{2} \times \frac{\quad}{2}$
 Fore 85% $\frac{I \times J}{2} \times 0.85 \times \frac{\quad}{2}$
 Measured Sail Area S
 \sqrt{S} for Formula

Rating According to Formula $\frac{L + \sqrt{S}}{4} + \frac{L \times \sqrt{S}}{12 \sqrt[3]{VD}}$ is :-

$\frac{\quad}{4} + \frac{\quad}{12x} \times \frac{\quad}{\quad} =$ Rating